

# PIONEER® Water Storage Tanks

*Built Stronger to Last Longer*



**ACER**  
**WATER TANKS**



**PIONEER**  
**WATER TANKS**

Master Dealer

## PIONEER® WATER STORAGE TANKS BUILT STRONGER TO LAST LONGER

*Our mission is to provide high-quality water storage products to meet the demands of a changing water landscape.*

*In a world where water supplies are becoming increasingly stressed, we believe functional and affordable water storage is an essential part of building sustainable water systems that provide users with the water they need for their domestic supply, agriculture, firefighting, and drinking water.*

*Water stress is economic stress is environmental stress. No other asset is as important as water.*

*Acer Water Tanks is proud to be "part of the solution." We are committed to the long-term development of a sustainable water market and we believe that water security is the foundation of nearly every other system society relies on to function. From agriculture to energy production to manufacturing, water lubricates the world we live in.*

### The Ideal Choice for Your Independent Water Supply

PIONEER® tanks are the most sought after tank for domestic water storage. Using a time-tested Australian design, PIONEER® Home & Ranch water tanks provide a proven, high quality product for a wide range domestic uses including fire protection, rainwater harvesting, seasonal creek harvesting, well water storage, livestock watering, long-term potable water storage and many more. If you need to store a large volume of water, PIONEER® is likely your best option.

The PIONEER® tank is known for being the best balance between *quality* and *affordability*, but what's most important to our customers is the *security* of their water supply. Whether the water is needed for the household, agriculture or fire protection, water is the most valuable asset on the land. We cannot live without it. When customers buy a PIONEER® Water Tank, they are buying peace of mind.

Let the experts at Acer Water Tanks help you find the best tank size and style for your independent water supply.





## A WIDE RANGE OF SIZES



PIONEER® XL 23/02 tank in Tucson, Arizona.

*PIONEER® Water Tanks are available in a wide range of sizes and capacities to suit your water storage needs.*

*The quality construction and refined look of the PIONEER® tank is unique to large storage tanks and we're proud of the way our tanks look and perform.*

*Our low-profile roof keeps obstruction of view to a minimum and PIONEER® tanks are available in silver and green, so you can decide if you'd like the tank to stand out as a feature of the landscape or blend in with the vegetation.*

*With the addition of a fascia kit, the look is further improved and the final product is very aesthetically pleasing.*

*Did you know that PIONEER® tanks are available in sizes up to 700,000 gallons? We offer a complete range of commercial grade tanks to meet the specifications of almost any project. Contact our commercial sales department to speak with someone about large scale water storage projects.*

### PIONEER® Water Tanks Standard Tank Sizes and Capacities

PIONEER® Tank Sizes	Tank Dimensions		Nominal Tank Volume*	
	Diameter	Height	US Gallons	Liters
XL 01/02	8'10"	7'2"	3,249	11,356
XL 04/02	11'0"	7'2"	4,990	18,927
XL 08/02	15'5"	7'2"	9,907	37,573
XL 15/02	22'0"	7'2"	20,243	76,680
XL 23/02	26'4"	7'2"	29,093	110,419
XL 30/02	30'9"	7'2"	39,626	150,292
XL 40/02	35'2"	7'2"	51,785	196,300
XL 50/02	39'6"	7'2"	65,567	248,442

We also offer custom sizes, not shown here (see p. 14 for capacity chart). Contact Acer Water Tanks to find out more about our complete range of tanks. Custom tanks have a lead time of approximately 120 days.

\*Capacity will vary in seismic regions.

## THE BEST LINER IN THE INDUSTRY

*Although the liner is hidden from sight and often doesn't get noticed unless there is a problem, we feel that it is perhaps the most important part of the tank which is why only AQUALINER® membranes are used in PIONEER® tanks.*

*With a superior quality tank liner, PIONEER® water tanks will stand the test of time. All standard PIONEER® water tanks are fitted with Pioneer's exclusive AQUALINER® water storage liner.*

*We are so confident of its superior performance that we give it our ten year warranty\* against leaking when used for potable water storage.*

*If your project requires the storage of liquids other than pure water, contact us to find out if one of our other liners may be suitable, such as the INDUSTRATEX® water tank liner, which can handle water with higher chlorides and some chemicals.*

Layer 1 - Clear Polyethylene Film  
Layer 2 - Green Advanced Polyolefin Coating (3 layer extrusion)  
Layer 4- Green Advanced Polyolefin Coating (3 layer extrusion)  
Layer 5- Black Polyethylene Film

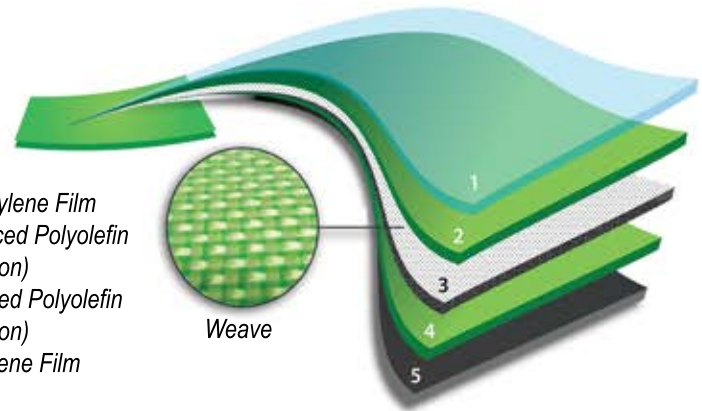

### The AQUALINER® Advantage

The AQUALINER® is the best liner in the water tank industry, hands-down. Unlike the liners in most water tanks, the AQUALINER® is made from a reinforced fabric with a woven center layer for strength and durability.

A clear polyethylene film coats both sides of the liner, giving the product NSF 61 approval for the storage of drinking water. The AQUALINER® is well-known for not imparting any taste or smell in the water, so when the quality of your water is paramount, choose AQUALINER®.

### Technical Highlights

AQUALINER® water storage liners feature five material layers bonded permanently together by hot melt-laminating the layers under pressure, creating a homogenous single liner. It is virtually impossible for the layers to separate under normal conditions. The closed protected environment that exists under the PIONEER® dome roof tanks is ideal. No harmful ultraviolet light and no movement result in a long life span for our AQUALINER® water storage liners.

### Rigorous Certification for Your Peace of Mind

The AQUALINER® water storage liner is ANSI/NSF 61 certified, NSF Certified Drinking Water System Components. This certification demonstrates that our AQUALINER® water storage liner has been rigorously tested by an independent body to internationally accepted standards. As a result, AQUALINER® water storage liners meet the requirements for stored water intended for human consumption, giving you peace of mind.

### INDUSTRATEX® Water Storage Liners

For heavy-duty commercial or industrial applications, we recommend the INDUSTRATEX® water storage liner. Speak with one of our experts to find out what liner will work best for your project.

## LOW PROFILE METAL DOME ROOF



29,173 gallon tank in Hawaii.



Roof truss construction.

### A Metal Dome Roof Offers Strength and Flexibility

Engineered roof structure design assures correctly proportioned structural elements and load transfer from the roof to the ground.

Plan of Tank

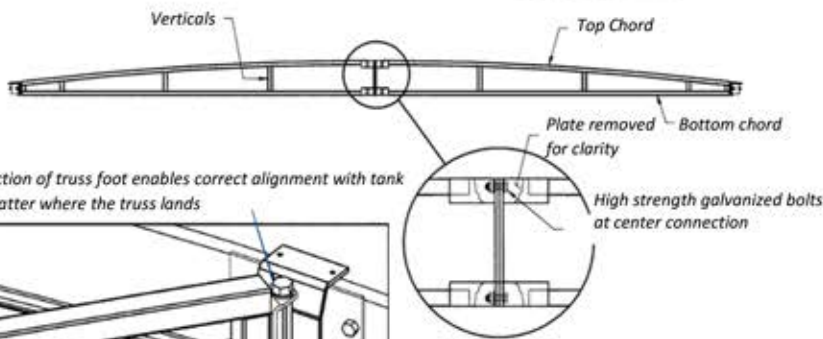
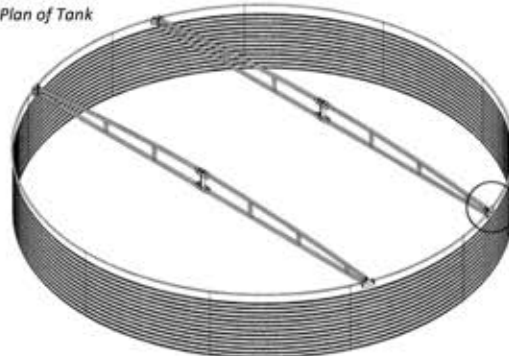

Pivoting action of truss foot enables correct alignment with tank wall, no matter where the truss lands

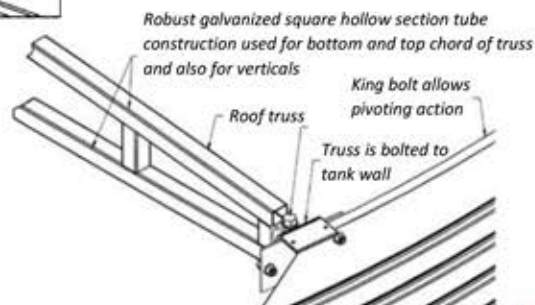
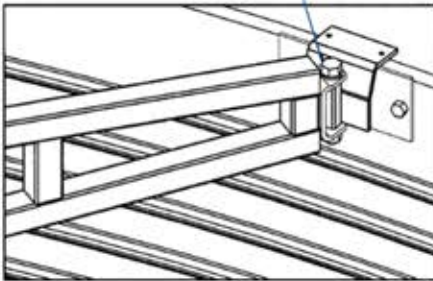

The components of the PIONEER® metal dome roof deliver a product that is strong, reliable, aesthetically appealing and flexible enough to suit most locations and water storage applications. The main features of the metal dome roof include:

- Heavy duty steel super structure.
- Dome shape drains away water, preventing standing water on the roof.
- Hot dipped galvanizing of all trusses and connections.
- A low profile that doesn't obstruct views and reduces cost by 30% versus competitor's tanks with sloped roofs.
- The ability to be custom made to suit existing concrete or steel tanks.
- Custom engineered roofs available for high and hurricane force winds and for seismic conditions.

## RAINWATER HARVESTING

*The practice of rainwater harvesting is an ancient technique that is becoming increasingly common in the United States and around the world. Scarcity of water resources, the inherent quality of rainwater and an interest in reducing consumption of treated water has increased the importance of rainwater harvesting globally. Rainwater is a sustainable source of water when groundwater or other sources are unacceptable or unavailable.*

*In general, the quality of rainwater is much higher than well water or city water. Water tests do not lie and rainwater scores high when compared to other sources of water.*

*Harvesting rainwater also reduces the volume of storm water that contributes to flooding, erosion and poor water quality during high-intensity rain events. Since the water is stored on site and eventually released back into the watershed, there is no loss of water within the overall water cycle.*



### Benefits of Rainwater Collection

- Rainwater is free; the only cost is for collection and use.
- The end use of harvested water is located close to the source, eliminating the need for complex and costly distribution systems.
- Rainwater provides a water source when groundwater or other water is unacceptable or unavailable, or it can augment limited water supplies.
- The zero hardness of rainwater helps prevent scale on appliances, extending their use.
- The use of rainwater eliminates the need for a water softener and the salts added during the softening process.
- Rainwater is sodium-free, important for persons on low sodium diets.
- Rainwater is superior for landscape irrigation.
- Rainwater harvesting helps utilities reduce the summer demand peak and delay expansion of existing water treatment plants.
- Rainwater harvesting reduces consumers' utility bills.

### Rainwater Collection Methods

#### **Rainwater Collection from House Roof Underground (Wet)**

This is the most popular method of rainwater collection because of its neat appearance. Water is channeled via PVC water pipe below ground and up into the tank through the filter basket. It is important that the tank entry point is a minimum 18 inches lower than the roof gutter and that the PVC pipe is sealed and watertight. Please note, the farther the tank is from the house, the greater the height differential required.

#### **Rainwater Collection from Shed Roof Overhead (Dry)**

All PVC water pipes are channeled through the filter basket mounted on the roof of the water tank.

## COMMERCIAL APPLICATIONS

### Municipal and Industrial Water Storage

Cities, towns and water cooperatives all need to store enough water to meet the varying water demands of the populations they serve. When selecting a storage tank, water managers must consider price per gallon, durability, serviceability, and aesthetic quality. PIONEER® COMMERCIAL water tanks are an obvious choice when all of these factors are considered.

### Fire Water Storage

When a fire starts, water needs to be available fast and at a high flow rate. More and more building codes are requiring dedicated fire water storage to meet the demands of sprinkler systems in buildings.

PIONEER® water storage tanks are ideally suited for water storage dedicated to fire suppression and can be configured with large diameter outlets and anti-vortex shields to efficiently deliver water when large pumps turn on, as well as level indicators and switches.

### Vineyards and Wineries

Water is essential for agriculture and food processing and being without high-quality water can mean the difference between a profitable or unprofitable year. Especially in the wine growing regions of the US, where rainfall is unpredictable and underground aquifers are being pumped faster than ever, water storage tanks provide insurance that water will be available on demand and without fail.



Industrial water storage tank.



Tanks fitted for municipal water storage.



Fire water tanks.



Water storage and solar panels, a truly sustainable winery.

*PIONEER® Commercial Tanks offer a heavy-duty configurable water storage solution for the most demanding projects. Built from high-quality Zincolume® steel and engineered to exacting specifications, our tanks are among the most durable in the industry.*

*PIONEER® Commercial Tanks are delivered to and built directly at the project site without the use of cranes, which reduces the overall project cost and allows for the most flexibility in adapting to the site's installation requirements.*

*When specifying a tank, we consider seismic zone, snow load factor and wind rating so your project is engineered to the highest standards.*

*If needed, PIONEER® tanks can be increased in volume by adding more rings to the tank or disassembled and moved to another location at a minimal cost.*

*Our proprietary tank liners, the AQUALINER® and INDUSTRIATEX®, can handle a wide range of variability in water chemistry. Because of this, we can supply tanks for water reclamation projects, aquaculture farms, mining operations and other applications requiring containment of special liquids.*

## SITE PREPARATION IS IMPORTANT

*PIONEER® water tanks are engineered to withstand hydrostatic pressure, high winds and some earth movement during seismic events. However, it's important to prepare the site properly to assure that your tank offers great performance over many years.*

*Please contact Acer Water Tanks or your Authorized Dealer before you begin preparing your site if you have any questions about these important requirements.*

*Please be aware that engineering services may be required to secure a site grading or building permit for your tank, and fees associated with these services are typically not included in the price of your tank. Furthermore, some municipalities require one or more inspections of the tank and associated fees are not included unless specified.*

### Concrete Ring Beam Construction

For a superior tank installation, a concrete ring beam is recommended. Anchoring the tank to concrete prevents movement due to seismic activity, wind and other factors. It also gives the tank a stable base to rest upon that won't erode over time.

Site grading is not typically included as part of the tank package, but your Authorized Dealer may provide this service.

Acer Water Tanks provides "typical" ring beam drawings during the estimation phase of the project, so you can get an accurate bid for the foundation work on your tank.

Once the tank has been purchased, our engineering team can evaluate the site conditions and provide a "for construction" ring beam drawing at an additional cost.



*An example of a well-constructed ring beam foundation.*



*Completed tank, ready for anchoring.*

### Sand Pads

Where permitted, the tank may be built on a sand pad as a cost-saving alternative to a concrete ring beam.

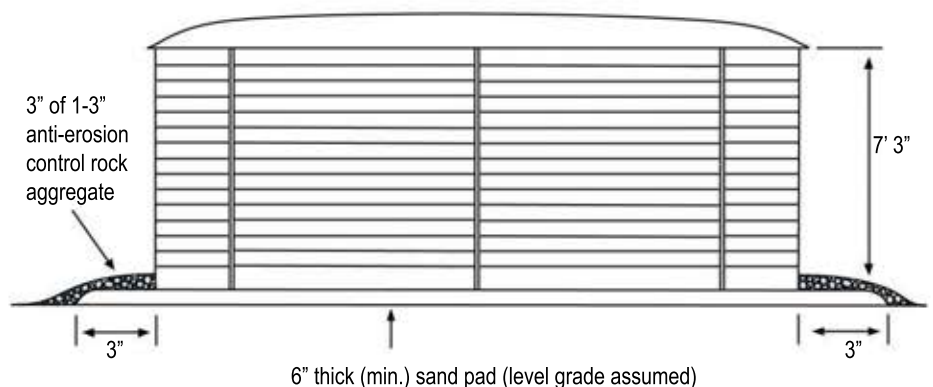

Drawing not to scale



## SIMPLE DELIVERY AND EFFICIENT INSTALLATION

### Personal Service for Your Installation

With our factory-trained installation team, Acer Water Tanks is able to install your tank almost anywhere. Remote locations and difficult terrain are not a problem. All installers are fully trained and experienced with building PIONEER® tanks in diverse environmental conditions.

Unlike large prefabricated tanks, which are costly to transport, difficult to handle and often require machines to unload from the transport vehicle to set in place, PIONEER® water tanks are palletized for easy transport. All parts of the tank can be manually unloaded and transported to nearby installation sites if needed. This dramatically reduces the cost of transport and installation, making PIONEER® water tanks the most affordable choice when all costs are calculated.

The installation process is managed by your local Authorized Dealer. It is their job to contact you prior to delivery to confirm your site conditions. They will also confirm an installation date, weather permitting. Your local Authorized Dealer will then coordinate the delivery and installation of your new tank.

It is preferable that you or your representative be on site when the installers arrive, to assure that the tank is oriented correctly. The inlet, outlet and overflow will then be located in the most economical and convenient position. To locate your nearest Authorized Dealer, please contact Acer Water Tanks at 877-223-7784.



*Acer's warehouse fully stocked with PIONEER® water tanks.*



*Standard PIONEER® tank kits fit comfortably on a single pallet.*



*A water tank packed and ready for delivery.*



*PIONEER® water tanks are easily installed on site by a well-trained crew.*

*PIONEER® water storage tanks' modular structure makes their delivery, assembly and installation considerably easier than installation of fiberglass or poly tanks construction of a concrete tank. Once packaged, our lightweight tanks can reduce to just 1% of their assembled size, so they fit neatly into a truck trailer or even a helicopter.*

*Standard tanks up to 65,000 gallons can be installed in less than one day- no fuss and no mess. Acer Water Tanks' fully trained installers are familiar with local conditions and terrain, which helps assure speedy installation.*

## EXTENSIVE STANDARD FEATURES

In addition to the AQUALINER® water storage liner and low profile metal dome roof, your PIONEER® water tank comes complete with an extensive range of standard features and accessories:

- Removable leaf and debris catchment filter.
- Removable ladder.
- Access hatch.
- Geotextile membrane.
- Pest and dust protection.
- Magnesium anodes to provide additional corrosion protection.
- Polyethylene outlets and shut off valves.
- Overflow pipe.

### Removable Leaf and Debris Basket Filter

A 1000-micron polyethylene basket filter prevents leaves and debris from entering your tank. The filter fits into the roof of the tank and lifts out simply for easy cleaning.



### Removable Ladder

A removable domestic style internal/external ladder is supplied with tank. The ladder enables tank access for general inspection and cleaning and also to easily check the water level. It can be removed to prevent unwanted access.

### Access Hatch

A lockable hinged access hatch opens easily to allow access to the interior of your PIONEER® water tank.

### Pest & Dust Protection

Your stored water is protected from dust and insects by installing a foam sealant between the roof and the top edge of the tank, creating a tight seal.

### Overflow Pipe

Standard PIONEER® water tanks are supplied with a six inch SDR overflow and PVC drainage pipe to channel excess water away from your tank's sand pad. The end of the overflow pipe includes a flapper valve to prevent insects and vermin from entering the overflow pipe.

### Magnesium Anodes to Provide Additional Corrosion Protection

By attaching sacrificial (or cathodic) magnesium anodes to PIONEER® water tanks, life is significantly extended. Electrolysis diverts to the magnesium, a more reactive metal, and gradually corrodes, leaving the steel wall intact. This is similar to how steel ships and oil rigs are protected by solid blocks of pure magnesium bolted to the hull below the water line. Under normal conditions, the anodes should be replaced every 10 years. When exposed to marine air, we recommend replacing every 5 years.

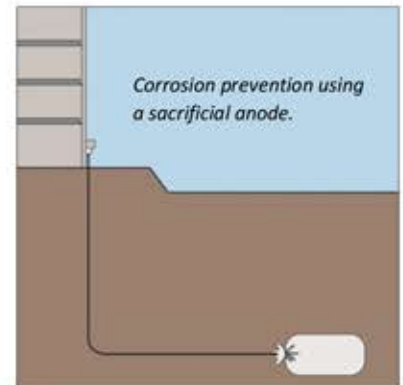

### Polyethylene Outlets & Shut Off Valves

Polyethylene fittings significantly reduce the risk of corrosion and assure a long serviceable life for your tank. Each PIONEER® water tank is supplied with high density a two inch outlet and ball valve. Larger fittings are available via special order.

## OPTIONAL ACCESSORIES

### Fascia

This unique fascia strip has been designed specifically with safety and aesthetics in mind. The fascia strip is fitted around the outside diameter of the tank where the corrugated steel roof sheeting finishes. The fascia complements the tank design and adds to the aesthetic appeal of the tank while covering the sharp roof



### Floating Suction Filter

This suction strainer floats about 12" below the surface of the water, removing the cleanest water from the tank. It provides protection for your pump from foreign objects which may be introduced into the tank. The floating ball is made of polyethylene and the filter is made of stainless steel. Sold with adapter that threads into the standard 2" PIONEER® tank outlet inside the tank.



### Liquidator 2 Water Level Gauges

We carry the Liquidator 2 water tank level gauge. The gauge's weighted float and indicator are connected to a counterweight by separate cords, each cord running over a pair of pulleys. At all times the indicator matches the water level exactly.

### Fire Hose Fittings

Many of our customers find value in having their PIONEER® water tanks as a potential firefighting source. We stock a range of firefighting fittings that provide instant access to fire reserve storage in case of emergency, for added peace of mind.



### Brass Outlet and Valve

We recommend switching to a brass outlet and valve if using a brass fire hose fitting. This eliminates any plastic fittings from the exterior walls of the tank where fire can potentially melt and damage them.



*Add value to your tank by outfitting it with high-quality products specifically chosen to integrate with the PIONEER® tank design.*

*We stock a full range of optional accessories to help you receive even more benefits from your PIONEER® water tank, such as:*

- *Fascia kit- improves aesthetic and safety of the tank.*
- *Floating suction filter- pulls cleanest water from tank and protects pump.*
- *Liquidator 2 water level gauges- shows the level of water in the tank.*
- *Fire hose fittings- provides direct access for fire-fighting.*
- *Brass outlet and valve- improves survivability of tank during a wildfire.*

*Acer Water Tanks can help you custom tailor a package of optional accessories to meet your water storage needs.*

*With over 20 years of proven performance in harsh climates around the world, PIONEER® water tanks live up to the high expectations of people who care about the quality of their water supply.*

*Be careful when reviewing the warranty provided by other tank manufacturers. You may see some others offering a 20-year warranty, but the fine print explains that they are actually offering a “prorated no-leak” warranty, rather than a full warranty like PIONEER®.*

*When installed and maintained properly, PIONEER® water tanks are designed for a service life of 30+ years. We are proud to revisit tanks installed decades ago and witness first-hand how well they stand up to the elements.*

### Complete 20-Year Warranty

All PIONEER® Tanks are professionally installed and come with a standard 20-year warranty on the entire tank, giving you peace of mind that your water storage will be around to serve your future needs.

Made of the highest-quality next generation Zincalume® steel and protected by a sacrificial anode system, PIONEER® tanks were designed with a 30-year service life in mind and are the most resistant steel tanks to corrosion. Replacing the anodes every 5 years will ensure that the tank walls stay strong and sturdy.

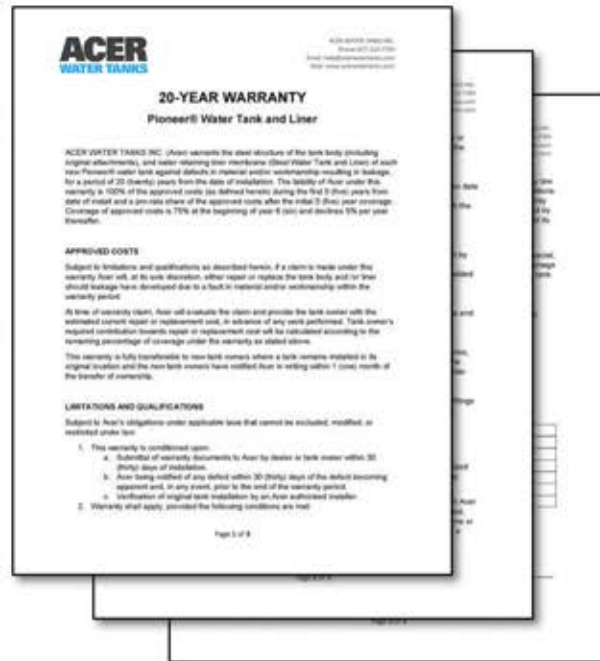

# PIONEER® WATER STORAGE TANKS



*This tank is part of a science exhibit that teaches visitors the value of rainwater collection.*



		PIONEER GALAXY® Gross Capacity (Gallons)							
		Number of Rings / Wall Height							
Tank Model	Tank Diameter	R1 3' 9"	R2 7' 2"	R3 10' 7"	R4 14'	R5 17' 5"	R6 20' 10"	R7 24' 3"	R8 27' 8"
XL01	8' 10"	1,714	3,249	4,813	6,363	7,913			
XL04	11'	2,678	5,076	7,521	9,942	12,364	14,786		
XL05	13' 2"	3,856	7,309	10,830	14,317	17,804	21,291	24,778	
XL08	15' 5"	5,226	9,907	14,678	19,404	24,130	28,856	33,582	
XL10	17' 7"	6,829	12,946	19,182	25,358	31,534	37,710	43,886	
XL13	19' 9"	8,647	16,392	24,287	32,107	39,927	47,747	55,567	63,387
XL15	22'	10,679	20,243	29,994	39,651	49,309	58,966	68,624	78,281
XL20	24' 2"	12,925	24,501	36,302	47,991	59,680	71,368	83,057	94,746
XL23	26' 4"	15,347	29,093	43,105	56,984	70,863	84,742	98,621	112,500
XL25	28' 7"	18,018	34,156	50,608	66,903	83,198	99,492	115,787	132,082
XL30	30' 9"	20,904	39,626	58,713	77,617	96,521	115,426	134,330	153,234
XL35	32' 11"	24,004	45,502	67,419	89,126	110,834	132,542	154,249	175,957
XL40	35' 2"	27,318	51,785	76,727	101,431	126,136	150,841	175,545	200,250
XL45	37' 4"	30,792	58,370	86,484	114,330	142,177	170,023	197,869	225,715
XL50	39' 6"	34,588	65,567	97,148	128,427	159,707	190,987	222,267	253,546
XL60	41' 8"	38,545	73,068	108,261	143,118	177,976	212,834	247,692	282,550
XL65	43' 10"	42,652	80,853	119,796	158,368	196,940	235,512	274,084	312,656
XL70	46'	46,900	88,906	131,727	174,141	216,555	258,968	301,382	343,796
XL80	48' 3"	51,630	97,872	145,012	191,703	238,395	285,086	331,777	378,468
XL85	50' 5"	56,367	106,852	158,317	209,292	260,267	311,242	362,217	413,192
XL90	52' 8"	61,465	116,515	172,635	228,221	283,806	339,391	394,977	450,562
XL100	54' 10"	66,703	126,446	187,349	247,672	307,995	368,318	428,641	488,964
XL110	57'	72,073	136,626	202,432	267,611	332,790	397,970	463,149	528,328
XL120	59' 2"	77,737	147,363	218,340	288,642	358,943	429,245	499,546	569,848
XL130	61' 5"	83,615	158,506	234,850	310,468	386,085	461,702	537,320	612,937
XL140	63' 7"	89,708	170,055	251,962	333,089	414,216	495,343	576,470	657,597
XL150	65' 9"	95,919	181,829	269,406	356,150	442,894	529,638	616,382	703,126

Contact our commercial sales department to speak with someone about large scale water storage projects. Custom tanks have a lead time of approximately 120 days. Capacity will vary in seismic regions.

# Fire- Water Tanks

## Discover the Difference with Pioneer® Fire-Protection Tanks

Combine your domestic and fire-water storage in one cost-effective, space-efficient tank.

Pioneer fire-protection tanks are designed to meet or exceed NFPA 22 standards for fire-water storage and come with a complete set of engineer-approved drawings.

Made of Zincalume® steel that has been proven to withstand fire immersion and resist corrosion, ensuring the safety of your water supply in even the worst emergencies.

The exclusive five-layer Aqualiner® is approved to NSF 61 standards for potable water.

Pioneer tanks can be configured for high-wind locales, seismic conditions, and heavy industrial zones with additional accessories that meet different compliance needs.

Optional anti-vortex and fire-fighting adapters ensure water is always available for quick access during a fire emergency.

Pioneer offers a wide variety of water-storage options with gross capacities ranging from 3,000 to 700,000 gallons.

Pioneer tanks are backed by our industry-leading 20-year warranty, so you can rest easy knowing you have a fire-protection solution that will last.

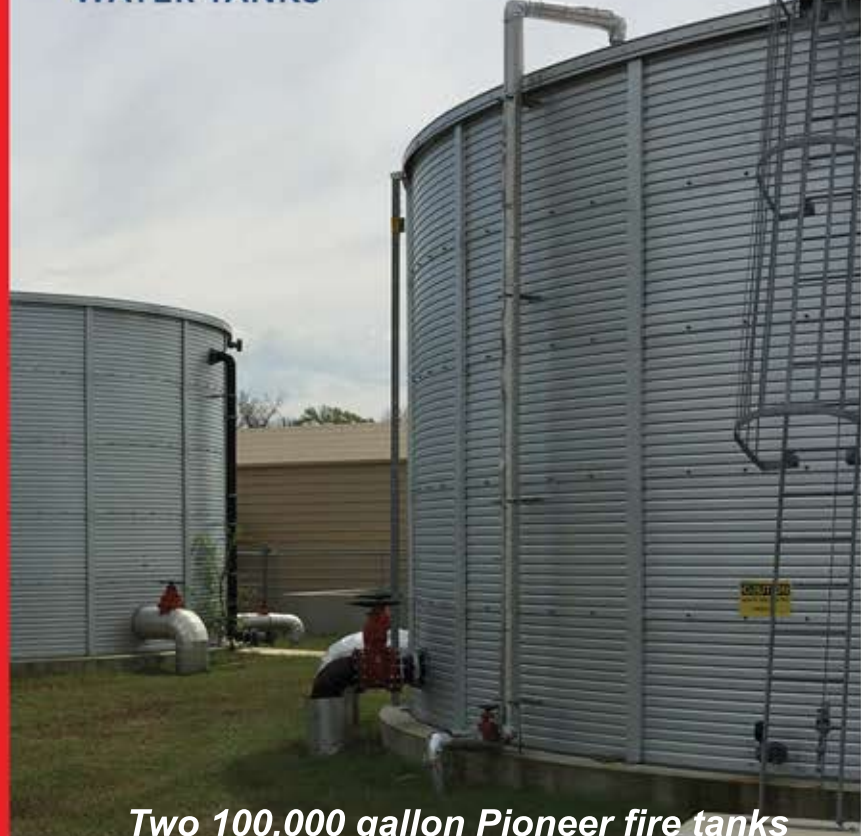

*Two 100,000 gallon Pioneer fire tanks  
at the First Responders Academy  
in San Antonio, Texas*



For more information contact Acer Water Tanks Inc.  
Phone: 877-223-7784  
Email: [orders@acerwatertanks.com](mailto:orders@acerwatertanks.com)  
On the Web: [www.acerwatertanks.com](http://www.acerwatertanks.com)





[www.acerwatertanks.com](http://www.acerwatertanks.com)

Connect with Acer Water Tanks:



[facebook.com/acerwatertanks/](https://facebook.com/acerwatertanks/)



[linkedin.com/company/acer-water-tanks](https://linkedin.com/company/acer-water-tanks)

*Acer Water Tanks is not a designer of water management systems or a consultant in relation to their use. All information in Acer Water Tanks' published literature is accurate to the best of the writer's knowledge. Acer Water Tanks will not be responsible for the consequences of any information in its published literature or any technical advice given by its employees in relation to the design, installation, and use of these products.*